

IN\_HBR/2.??

ENABLE\_BRIDGE/2.??

U1

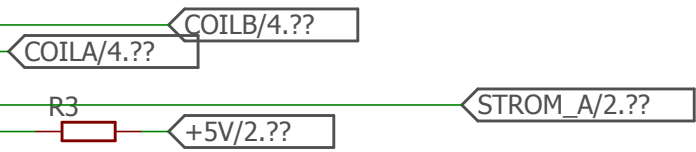

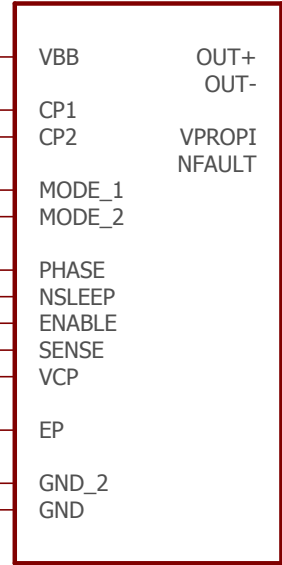
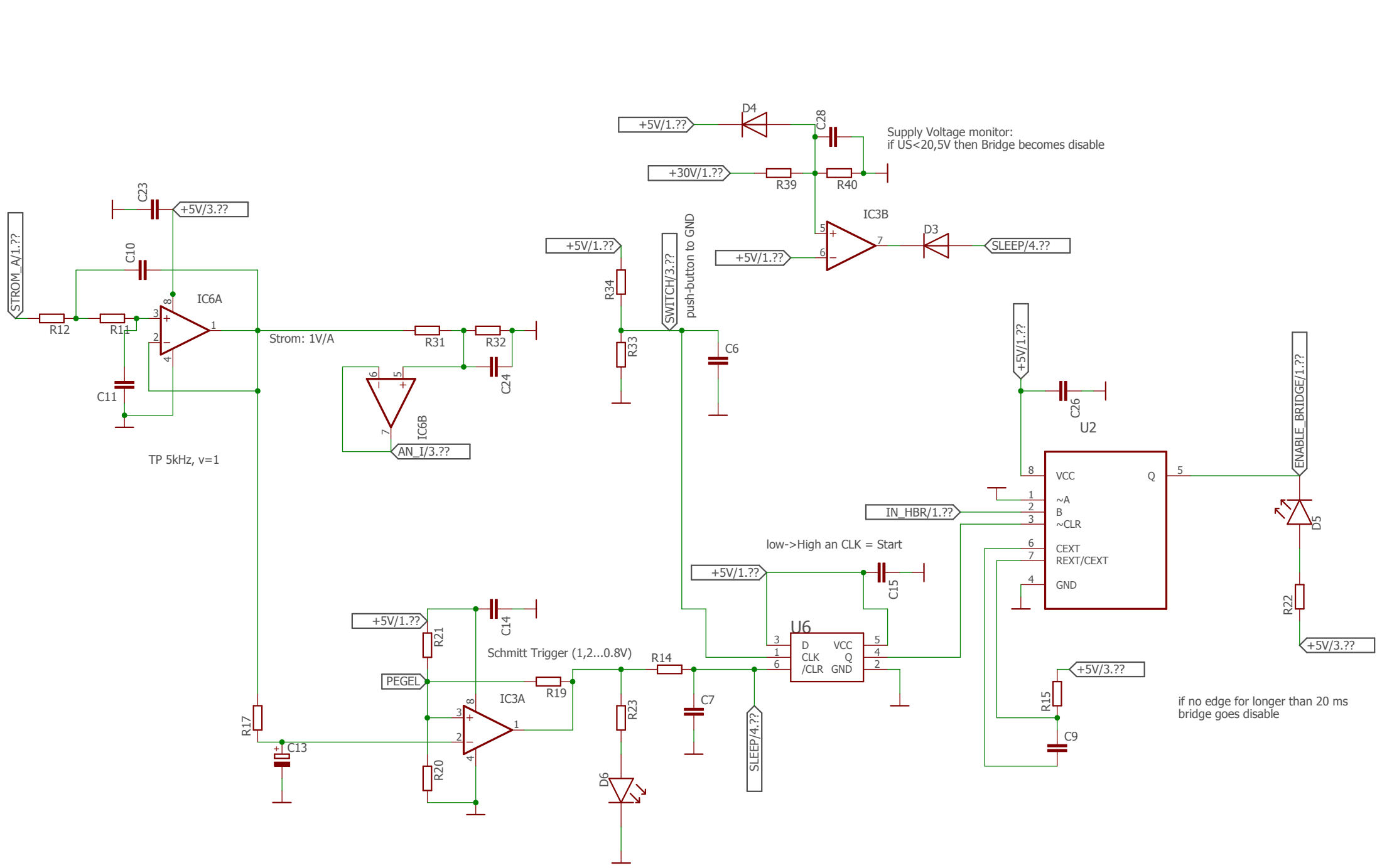

TP 5kHz, v=1

Schmitt Trigger (1,2...0.8V)

low->High an CLK = Start

Supply Voltage monitor:  
if  $US < 20,5V$  then Bridge becomes disable

if no edge for longer than 20 ms  
bridge goes disable

